



DROGARIA CENTRAL

Bernardo Peixoto da Mota e Filhos, Lda

Rodas Em NYLON



DROGARIA CENTRAL

Bernardo Peixoto da Mota e Filhos, Lda

Roda de nylon com casquilho e eixo em aço zincado

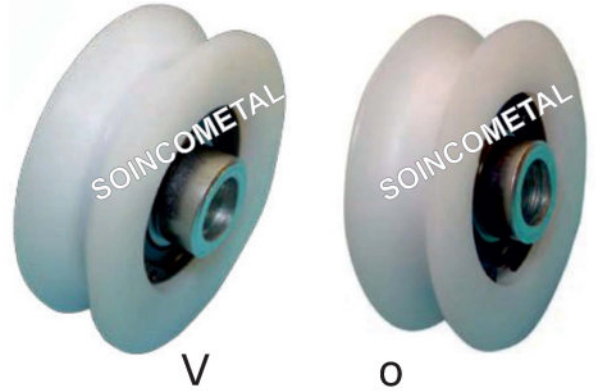
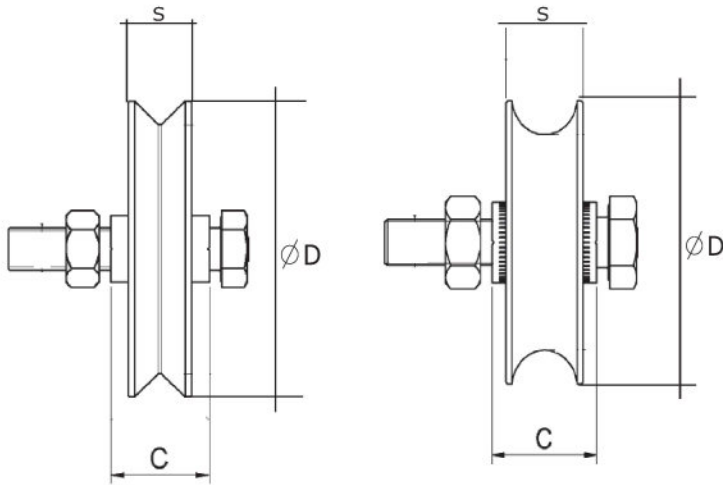

| Referência | DØ | S | Tipo de gola | C | Nº rolamentos | Peso suportado | Qt p/caixa | Preço/un |
|--------------|-----|----|--------------|----|---------------|----------------|------------|----------|
| 824 16 O NY | 80 | 24 | Ø 16 | 33 | 1 | 100 kg | 6 | 11.20 € |
| 824 20 O NY | 80 | 24 | Ø 20 | 33 | 1 | 100 kg | 6 | 11.20 € |
| 827 O NY* | 80 | 27 | Ø 20 | 37 | 1 | 100 kg | 6 | 10.03 € |
| 1023 O NY* | 100 | 23 | Ø 16 | 37 | 1 | 100 kg | 6 | 11.97 € |
| 1024 20 O NY | 100 | 24 | 20 | 24 | 1 | 100 kg | 6 | 13.20 € |
| 1027 O NY* | 100 | 27 | Ø 20 | 37 | 1 | 100 kg | 6 | 11.97 € |
| 1227 O NY* | 120 | 27 | Ø 20 | 37 | 1 | 100 kg | 4 | 13.24 € |
| 824 V NY | 80 | 24 | V | 33 | 1 | 100 kg | 6 | 11.20 € |
| 1024 V NY | 100 | 24 | V | 33 | 1 | 100 kg | 6 | 13.20 € |
| 1026 V NY* | 100 | 26 | V | 37 | 1 | 100 kg | 6 | 11.97 € |

Roda de nylon com casquilho e eixo em aço inox - AISI 304

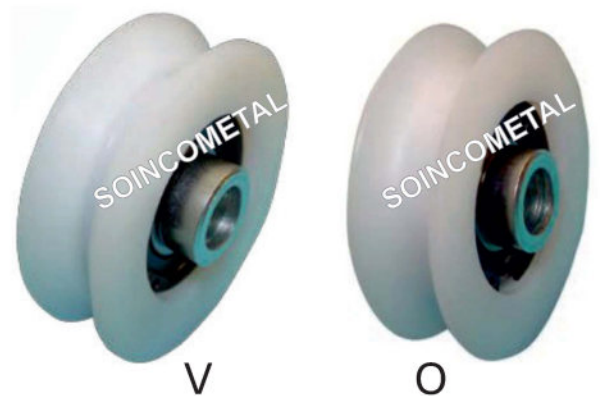
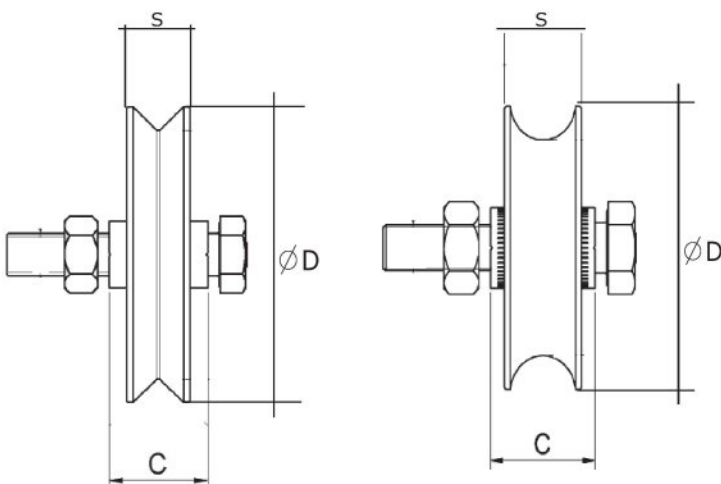

| Referência | DØ | S | Tipo de gola | C | Nº rolamentos | Peso suportado | Qt p/caixa | Preço/un |
|---------------|-----|----|--------------|----|---------------|----------------|------------|----------|
| 827 O NY IN* | 80 | 27 | Ø 20 | 37 | 1 | 100 kg | 6 | 14.93 € |
| 1023 O NY IN* | 100 | 23 | Ø 16 | 37 | 1 | 100 kg | 6 | 16.87 € |
| 1027 O NY IN* | 100 | 27 | Ø 20 | 37 | 1 | 100 kg | 6 | 16.87 € |
| 1227 O NY IN* | 120 | 27 | Ø 20 | 37 | 1 | 100 kg | 4 | 18.14 € |
| 1026 V NY IN* | 100 | 26 | V | 37 | 1 | 100 kg | 6 | 16.87 € |



DROGARIA CENTRAL

Bernardo Peixoto da Mota e Filhos, Lda

Roda de nylon com suporte em aço zincado

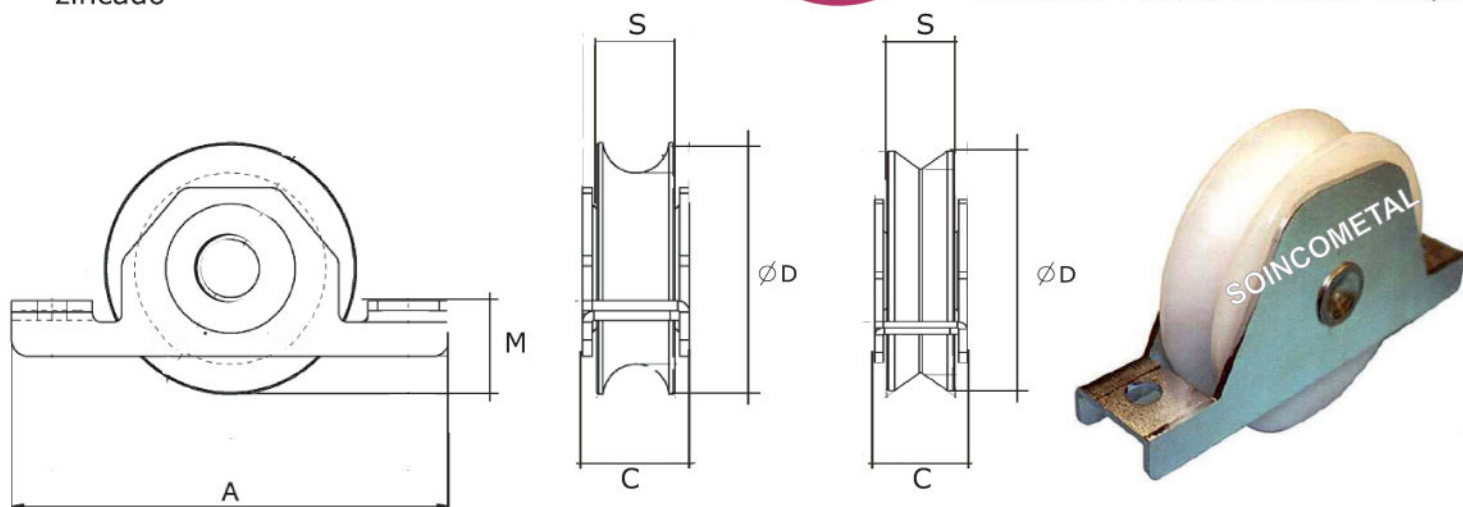

| Referência | Ø | S | Tipo de gola | C | A | M | Nº rolamentos | Peso suportado | Qt p/caixa | Preço |
|---------------|-----|----|--------------|------|-----|----|---------------|----------------|------------|---------|
| 824 16 PSO NY | 80 | 24 | Ø 16 | 33 | 135 | 29 | 1 | 100 kg | 6 | 13.20 € |
| 824 20 PSO NY | 135 | 24 | Ø 20 | 33 | 135 | 29 | 1 | 100 kg | 6 | 13.20 € |
| 1027 PSO NY* | 100 | 27 | Ø 20 | 34,8 | 158 | 39 | 1 | 100 kg | 2 | 13.81 € |
| 824 PSV NY | 80 | 24 | V | 33 | 135 | 29 | 1 | 100 kg | 6 | 21.20 € |
| 1024 PSV NY | 100 | 27 | V | 33 | 155 | 32 | 1 | 100 kg | 6 | 25.20 € |

Roda de nylon com suporte em aço inox - AISI 304

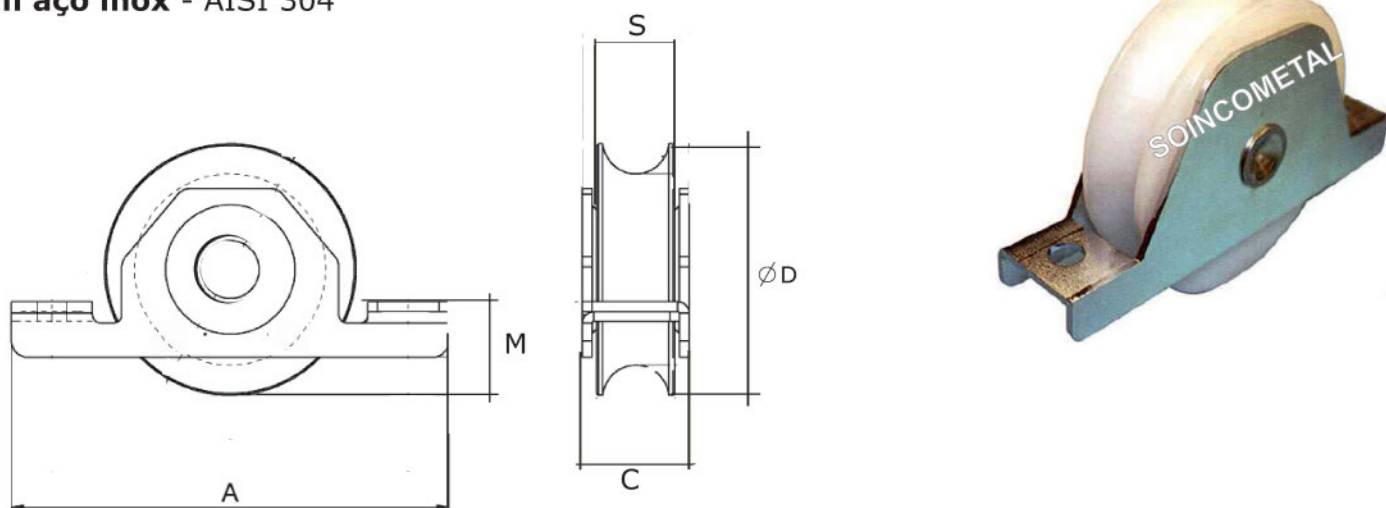

| Referência | Ø | S | Tipo de gola | C | A | M | Nº rolamentos | Peso suportado | Qt p/caixa | Preço |
|-----------------|-----|----|--------------|------|-----|----|---------------|----------------|------------|---------|
| 1027 PSO NY IN* | 100 | 27 | Ø 20 | 34,8 | 158 | 39 | 1 | 100 kg | 2 | 29.20 € |

* Material até final de stock

Preços sujeitos a alteração sem aviso prévio
Os preços entendem-se à saída do nosso armazém e são acrescidos de IVA

Março 2017

